



Recreational Vehicle and Marine Whole Vehicle Water Filtration

Models WV-B2, WV-A3, and WV-B3

Like most people, your concerns about water quality have probably increased over the past few years. Daily, there are news reports on water contaminations. Every time you reach a new location and hook-up to the water supply, you meet a new set of water quality conditions. Therefore, you need a solution that helps address your concerns.

**WV Series Systems filter ALL incoming water...to be sure!!
Having cleaner, good tasting water was never this easy.**



All Systems:

- Install on the main line for all the water in your vehicle
- Feature our exclusive Sanitary Quick Change Design
- Easy Cartridge Change
- Patented Carbon Block for improved absorption
- Patented Interconnect for ease-of-use and positive sealing
- 6 Month Cartridge Life
- Bacteria inhibitor built-in, intended to reduce fouling of media
- Saves on the cost and storage of bottled water
- Reduces total vehicle weight, improving gas mileage, by eliminating stored water
- Locking tab securely fastens cartridge in place
- 1/2" NPT Connections

3M Taste and Odor Systems (WV-A3):

- Provides cleaner, better tasting and smelling water throughout your vehicle
- WV-A3 (at 3.5+ gpm) connects to main line for drinking, cooking and bath water
- Reduces greater than 95% of Chlorine
- Reduces sediment, dirt, rust, sand and silt to 1 micron

3M Biological Reduction Systems (WV-B2 and WV-B3):

- Minimize Concerns Of Biological Contamination, while improving the taste, smell and clarity of your water supply
- Patented Dual-Zone Nylon Membrane Bacteria Barrier
- WV-B3 (at 3.5+ gpm) and WV-B2 (at 2.5+ gpm) connect to main line for drinking, cooking and bath water
- WV-B2 may also be installed as an undersink filter for all the water at your kitchen sink
- Reduces up to:
 - 99.99% of Bacteria¹ - 99.99% of Algae³ - 99.99% of Parasitic Protozoan Cysts² - 99.99% of Mold Spores³
- Reduces greater than 95% of Chlorine
- Reduces sediment, dirt, rust, sand and silt to 0.2 micron

1 As tested with either E.Coli ATCC (11229) or Pseudomonas (B) diminuta ATCC (19146) [As tested by CUNO Incorporated. Not tested or certifiable by NSF International.] / 2 As tested in accordance with NSF/ANSI Standard 53 / 3 As tested with Dekkera bruxellensis ATCC (64276) [As tested by CUNO Incorporated. Not tested or certified by NSF International.]

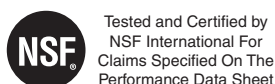

The Solution for ever-changing water supplies.



Whole Vehicle Filter Systems

Physical Specifications:

- Includes a head assembly with integral mounting bracket with locking tab, and a single cartridge filter.
- Inlet and outlet plumbing connections are 1/2" NPT.
- System maximum operating pressure of 125 psi (862 kPa) and operating temperature of 100°F (38°C).
- Filter cartridges incorporate carbon block media protected by a pleated pre-filter membrane.
- System is NSF Standard 42 and 53 and/or FDA CFR-21 compliant.
- Cartridge body is constructed from high-impact glass-filled polypropylene.
- Cartridges are sanitary in design, requiring no contact with the filter media during cartridge change-out.
- Filter cartridges are ready to use.

WARNING

- **Do not use with water that is microbiologically unsafe or of unknown quality without adequate disinfection before or after the system.** Systems certified for cyst reduction may be used on disinfected water that may contain filterable cysts. EPA Establishment Number 070595-CT-001.
- Do not use the system if the filter cartridge has been contaminated with any winterizing chemicals. A new filter cartridge must be installed when opening system for use after winterization.

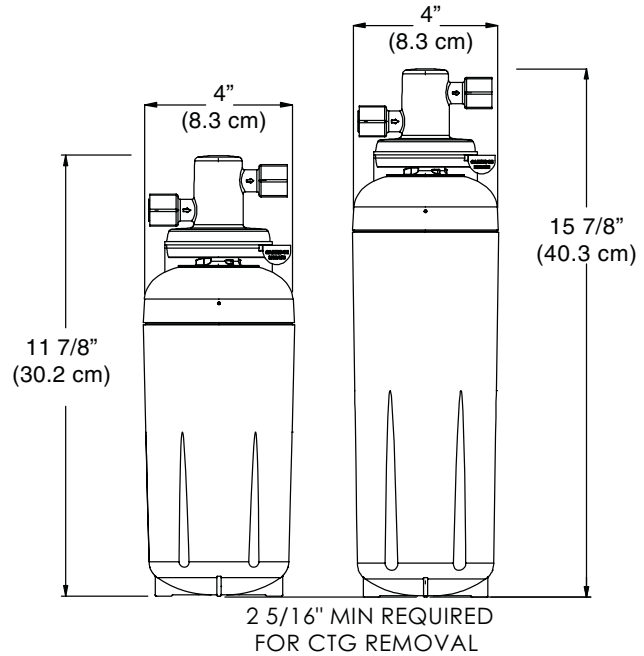

CAUTION:

To reduce the risk associated with property damage due to water leakage:

- Read and follow installation and use instructions.
- **Protect from freezing.** Remove filter cartridge when temperatures are expected to drop below 40°F (4.4°C).
- Install on **COLD** water lines only.
- Follow accepted plumbing practices such as those outlined in the Uniform Plumbing Code.
- Install a pressure limiting device and water hammer arrester for inlet water pressures exceeding 80 psi. (Refer to Uniform Plumbing Code, Sections 608.2 and 609.10)
- Never install or operate where inlet water pressure may exceed maximum operating psi.
- Replace cartridge every season. Cartridge **MUST** be replaced at least every 12 months.

Model Number	Cartridge Included	Capacity	Flow Rate	Sediment	Chlorine	Bacteria ¹	Parasitic Cysts ²	Algae ³	Mold Spores ³
WV-B2	B2	7,500 gal (28,390 lit)	2.5 gpm (9.4 lpm)	0.2 micron	> 95%	99.99%	99.99%	99.99%	99.99%
WV-B3	B3	15,000 gal (56,781 lit)	3.5 gpm (13.2 lpm)	0.2 micron	> 95%	99.99%	99.99%	99.99%	99.99%
WV-A3	A3	15,000 gal (56,781 lit)	3.5 gpm (13.2 lpm)	1 micron	> 95%	No	No	No	No

Replacement cartridges listed below can be used in any system listed above.

Cartridge Included	Capacity	Flow Rate	Sediment	Chlorine	Bacteria ¹	Parasitic Cysts ²	Algae ³	Mold Spores ³
B3	15,000 gal (56,781 lit)	3.5 gpm (13.2 lpm)	0.2 micron	> 95%	99.99%	99.99%	99.99%	99.99%
A3	15,000 gal (56,781 lit)	3.5 gpm (13.2 lpm)	1 micron	> 95%	No	No	No	No
B2	7,500 gal (28,390 lit)	2.5 gpm (9.4 lpm)	0.2 micron	> 95%	99.99%	99.99%	99.99%	99.99%

1 As tested with either E.Coli ATCC (11229) or Pseudomonas (B) diminuta ATCC (19146) [As tested by CUNO Incorporated. Not tested or certifiable by NSF International.] / 2 As tested in accordance with NSF/ANSI Standard 53 / 3 As tested with Dekkera bruxellensis ATCC (64276) [As tested by CUNO Incorporated. Not tested or certified by NSF International.]

3M™ Recreational Vehicle/Marine Filter Systems and Filter Cartridges 5 Year Limited Warranty

3M Company ("3M") warrants its residential recreational vehicle/marine filter systems and filter cartridges ("Product(s)") to be free from defects in material and workmanship during normal use for a period of five (5) years from the date of original purchase. If the Product(s) is (are) defective within this warranty period, your exclusive remedy and 3M's sole obligation shall be, at 3M's option, to replace or repair the Product(s) or refund the original purchase price of the Product(s). This warranty does not apply to failures that result from abuse, misuse, alteration or damage not caused by 3M or failure to properly follow installation and use instructions.

To obtain warranty service, contact 3M at 888-724-6326. Proof of purchase (original sales receipt) must accompany all warranty claims, along with a complete description of the product, model number, and defect.

Limitation of Liability. 3M will not be liable for any loss or damage arising from the use of this Product(s), whether direct, indirect, special, incidental, or consequential, regardless of the legal theory asserted, including warranty, contract, negligence or strict liability. Some states do not allow the exclusion or limitation of incidental or consequential damages, so the above limitation may not apply to you.

This warranty gives you specific legal rights and you may have other rights which vary from state to state, or country to country.

Manufactured by CUNO Incorporated, a 3M Company

400 Research Parkway, Meriden CT 06450 U.S.A. • 888-724-6326 • 203-238-8701 • www.rvmarinewater.com